

TECHNICAL BULLETIN 8.4

issued: 10/2015

Application Methods for **Avery Dennison®** Screen self-adhesive films

Avery Dennison® self-adhesive films are available in a wide range of qualities for many different applications. Application of these films has to be done in the best possible manner: this will ensure the product will perform as expected. Successful application results in an adequate bond between adhesive and the substrate. Please read the instructions for substrate preparations first before application of decals.

Substrate preparation:

A substrate has to be cleaned by:

1. Washing with a mild detergent solution, after which the surface should be rinsed and dried with a lint free cloth.
2. Wiping with a solvent-saturated cloth, until all dirt and/or grease has been removed. The solvent should be sufficiently mild not to attack the substrate (e.g. methylated spirits).

Many commercially available cleaning/degreasing products exist: the applicator should establish the suitability of a product prior to actual use. In addition, the following factors should be considered prior to decal application:

- Bare metals can best be prepared for decal application by cleaning with a detergent solution, followed by solvent cleaning with a (solvent) saturated cloth. Solvents that can be used include: white spirit, heptane or other suitable degreasing solvents.
- Car wax and polish residues must be completely removed.
- Paint surfaces must be completely dry and hardened. On most baked paints; decals can be applied immediately after cooling down. Air dried paints and car repair paint require at least week to dry out before decals are applied. Solvent residues in painted substrates which are not completely dry may adversely affect decal adhesion, and can cause excessive shrinkage or blistering.
- Painted substrates which will act as a substrate for self-adhesive decals should be applied according to the paint manufacturer's instruction. Here too it is important to avoid solvent retention. Paint system components that are not compatible or that do not adhere properly to each other may cause paint to be lifted when decals have to be removed after use.

Self-adhesive films have various degrees of flexibility/conformability. On three dimensionally shaped surfaces a cast film generally gives the best results. The use a hairdryer will improve the conformability and reduce the tendency for films to delaminate or lift. Always respect the minimum application temperatures as given in the technical datasheets.

Please consider that all monomer Films are only recommended for vertical flat application, if application on curves or edges needed please use polymeric or cast films.

TECHNICAL BULLETIN 8.4

Small size decals

Place the decal upside down on a flat surface. Remove the liner along one edge for 2-3 cm and fold it backwards as shown in the drawing. The result is an edge of 2-3 cm exposed adhesive.

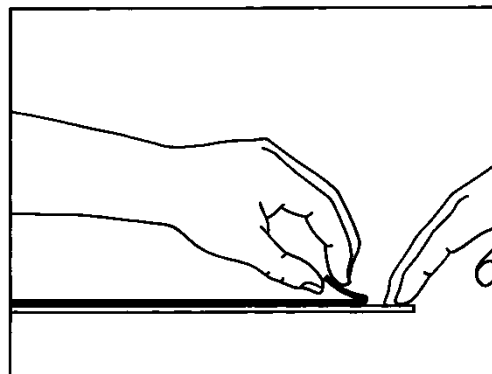

Position the decal that is still covered with liner on the application surface. Once it is in the right position, the exposed edge is pressed to the surface, starting at the middle of the edge, working your way up and down. Do not allow pleats or bubbles to be formed.

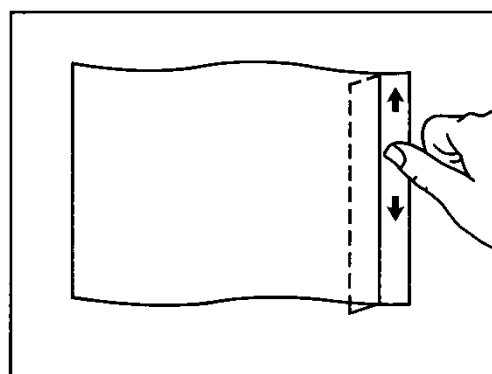

Lift the decal a bit and remove the liner over 15-20 cm (or more if you feel experienced enough) distance. Keep the decal close to the application surface and start to apply it with overlapping squeegee strokes, beginning at the middle of the already applied edge. Proceed with this application until the entire decal is applied.

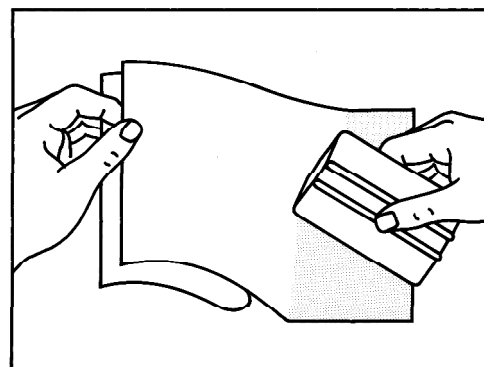

Check if all edges have been applied properly and re-squeegee them if necessary. Bubbles can be punched with a needle and the air can be removed by pushing it through the hole, starting at the edges of the bubble.

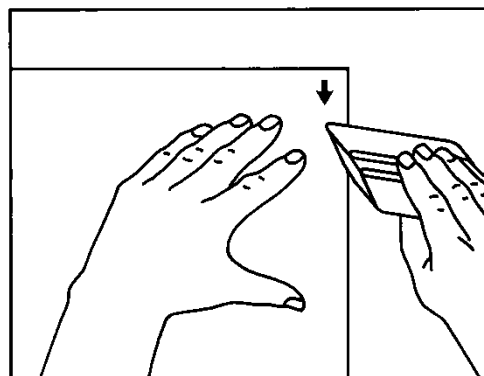

TECHNICAL BULLETIN 8.4

Medium size decals

Apply reference marks on the application surface so that the position of the decal to be applied can easily be identified. Masking tape or easily erasable markers will generally do this job.

Place the decal upside down on a flat surface. Remove the liner along one edge for 2-3 cm and fold it backwards as shown in the drawing. The result is an edge of 2-3 cm exposed adhesive.

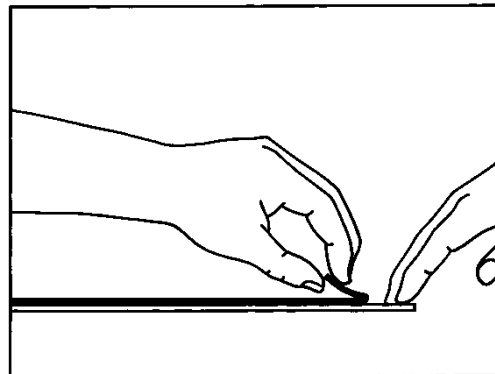

Take the decal up close to the exposed edge and position the decal on the application surface, making sure it lines up with the reference marks.

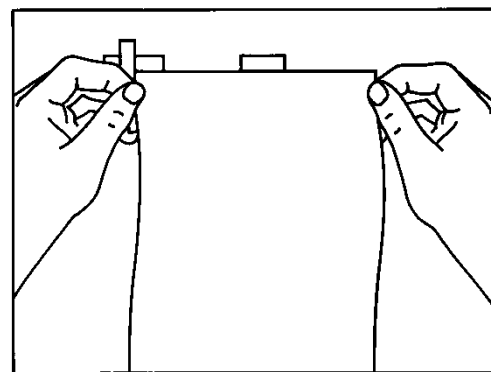

Then the exposed edge is pressed to the surface, starting at the middle of the edge working your way up and down (or left to right (as shown on this picture)). Do not allow pleats or bubbles to be formed.

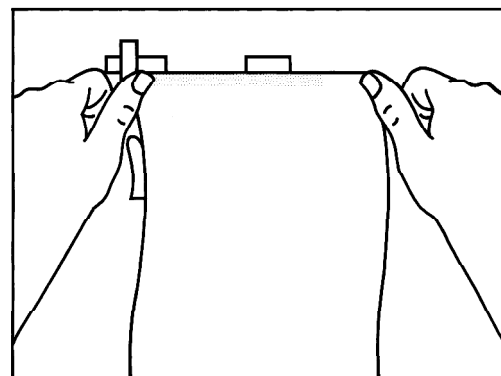

TECHNICAL BULLETIN 8.4

Lift the decal a bit and remove the liner over 15-20 cm (or more, if you feel experienced enough) distance. Keep the decal close to the application surface and start to apply it with overlapping squeegee strokes, beginning at the middle of the already applied edge. Proceed with this application until the entire decal is applied.

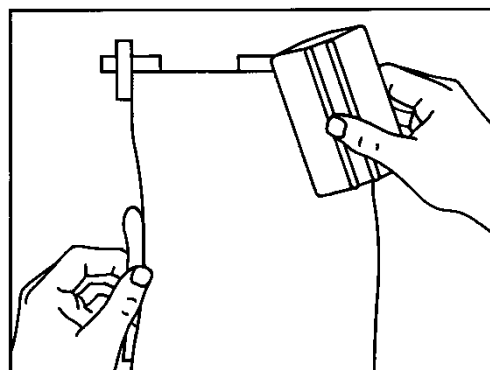

Check if all edges have been applied properly and re-squeegee them if necessary. Bubbles can be punched with a needle and the air can be removed by pushing it through the hole, starting at the edges of the bubble.

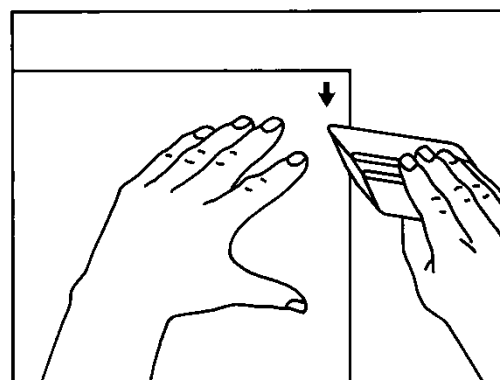

Large size decals

Position the decal, which liner is still present, to the application surface and fix it on the top edge with small strips of masking tape. Make sure that indeed the position is correct.

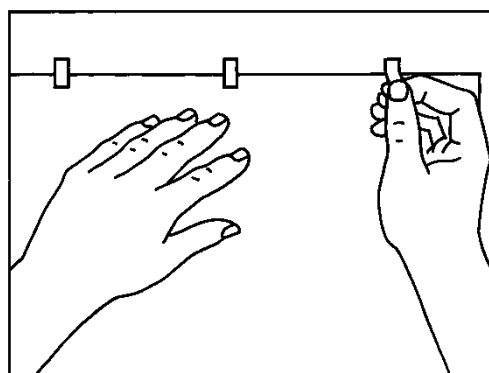

Apply a strip of masking tape over the full length of the edge, either on the right or on the left side of the decal. This strip should hold the decal in the correct position if the positioning masking tape strips are removed. If necessary, apply an extra strip of masking tape, overlapping the first one for some 50 %.

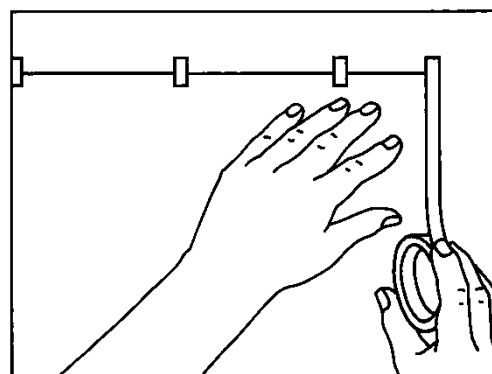

TECHNICAL BULLETIN 8.4

Remove the positioning strips from the top edge. Flip the decal over at the now formed hinge, and remove the liner over a 20-30 cm wide area parallel to the hinge. Fold the liner slightly so that the adhesive remains exposed.

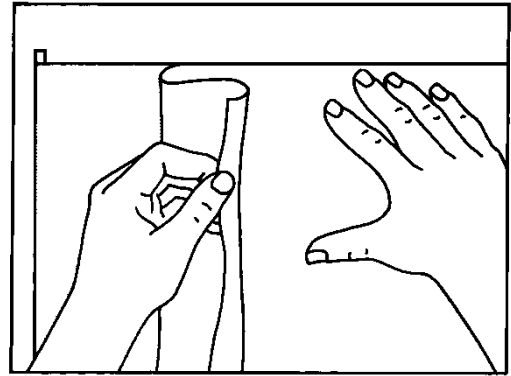

Flip the decal over and start to apply it at the hinge, making use of a hard plastic squeegee. Apply with overlapping squeegee strokes, from the middle of the hinge to the top and bottom decal edges.

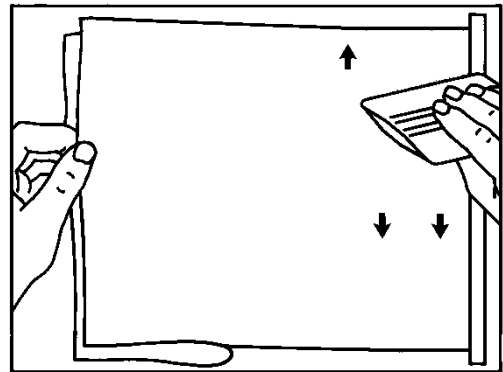

Proceed with application step by step, removing liner and applying the decal alternatively until the entire decal has been applied. Then remove the hinge and check and resqueegee all decal edges.

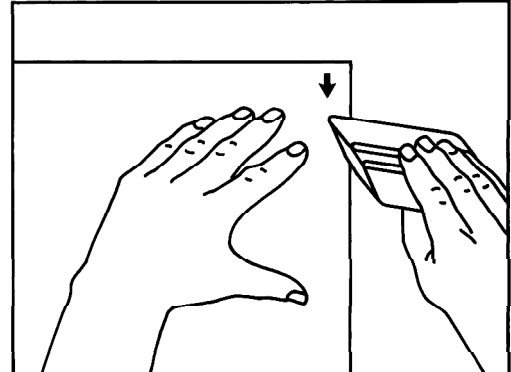

TECHNICAL BULLETIN 8.4

Wet application

Large-format stickers can also be applied wet.

This method of application is, however, less advantageous than dry application and demands special attention to the following points:

- Initial adhesion is considerably weaker.
- Full adhesion is not reached until much later and the sticker cannot be subjected to normal stress during this time.
- Dry application should therefore always be given preference wherever possible.

If dispersion-based adhesives, come into contact with water, they will become turbid after a time. This turbidity is, however, only temporary and will disappear once there is no further moisture trapped between the adhesive and the film and/or surface.

Neither the adhesive itself nor the ultimate strength and permanence of its adhesion will be adversely affected by the ingress of moisture.

Note:

Greenline with permanent adhesive is only for dry application recommended.

If you apply Greenline permanent adhesives outside there is the possibility that the edges will roll up after heavy rainfalls.

Ensure that the ambient temperature is high enough to allow the residual moisture to evaporate and escape to atmosphere via the adhesive and the film.

One of the factors which decisively influences the evaporation of this residual moisture is the water vapour permeability of the film. This varies considerably from one film to the next and is governed primarily by the specific properties of the film.

Considerable differences exist, for example, between a PVC film, such as Avery Dennison® and a PP film, such as Avery Dennison® Greenline. Flexible PVC films are much more permeable to water vapour than PP films. This means, in practical terms, that it will take longer for turbidity to disappear in the case of a PP film than in the case of a PVC film.

In order to reduce turbidity as far as possible when applying PP film, add less wetting agent (**baby shampoo**) to the water and take care to squeegee as much water from underneath the film as possible. Failure to observe this rule will result in considerable turbidity and this might not disappear even after several weeks.

Wet application, therefore, should be done only under the following conditions:

- During the warmer months of the year
- At temperatures of 20°C and over
- In dry weather
- Only in cases where the film, once it has been applied, can be protected against heavy moisture for at least 24 hours and then pressed down again (if possible, vehicle stickers should be applied on the last working day of the week and left to dry over the weekend)
- Only if surfaces are absolutely smooth and level.
- Protect the edges of the sticker against ingress of moisture.

DISCLAIMER

All Avery Dennison statements, technical information and recommendations are based on tests believed to be reliable but do not constitute a guarantee or warranty. All Avery Dennison products are sold with the understanding that purchaser has independently determined the suitability of such products for its purposes.

All Avery Dennison's products are sold subject to Avery Dennison's general terms and conditions of sale, see <http://terms.europe.averydennison.com>